

APPROVAL - CUSTOMER NAME & SIGNATURE

DATE

REV.	DATE	DRAWN	REVISION	PART NUMBER	MATERIAL	FINISH			
A	12JAN93	KPL	PRN: S-1-03	E3-27-1	NYLON	BLACK			
B	04SEP2001	VNI	PRN: P2001-0474						
C	11MAR2002	JWJ/AJH	PRN: P2002-0131						

NOTES:
 A. WHEN USING PULL TAB, MINIMUM AND MAXIMUM GRIPS OF FASTENERS ARE REDUCED BY 2.4mm [.093].

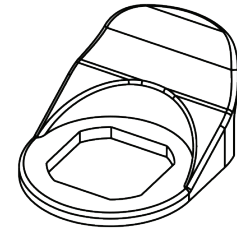
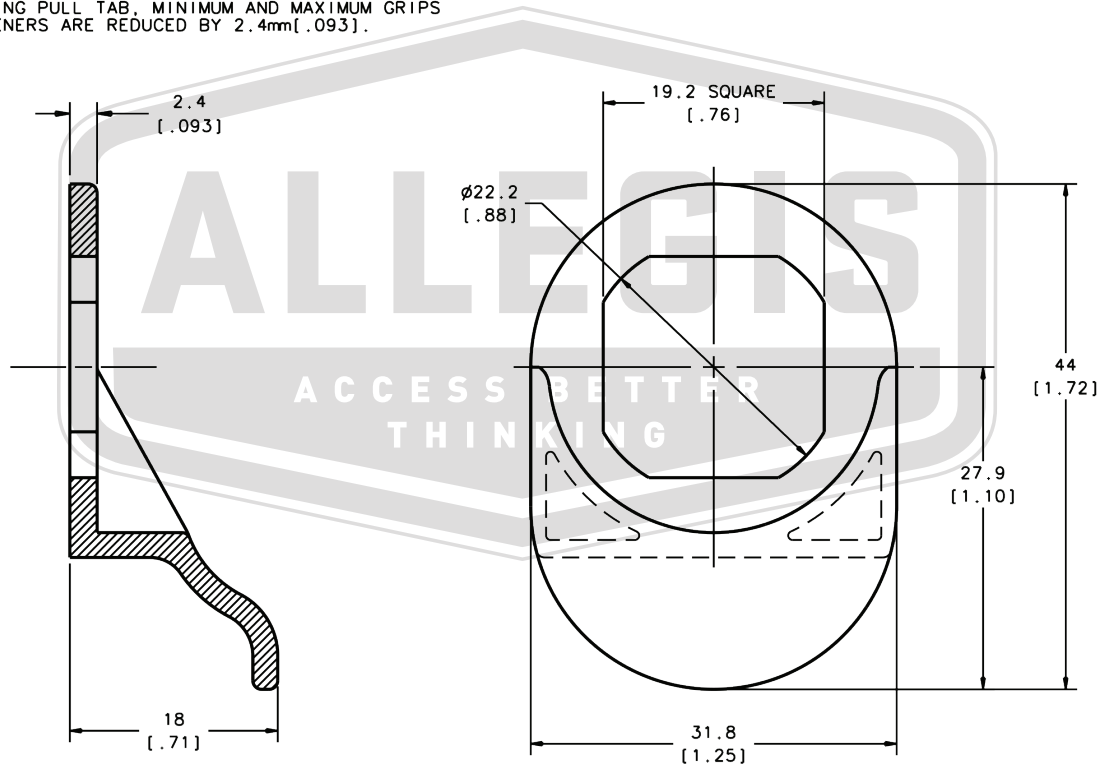

SCALE 1:1

ALLEGIS		1-866-378-7550
MATERIAL:	Plastic	DRAWING NO. : E3-27-1
FINISH:		
REV.:	1:1	DATE: 5/29/2019